

ORIGINAL INSTALLATION OR  
REPLACEMENT INSTRUCTIONS FOR

# Super Guard Lock<sup>®</sup> II

*THE WORLD'S STRONGEST LOCK*  
FOR INSWINGING DOORS 1-3/8" TO 1-3/4" ONLY

DB9286AP AUTOMATIC SINGLE  
CYLINDER JIMMY PROOF LOCK

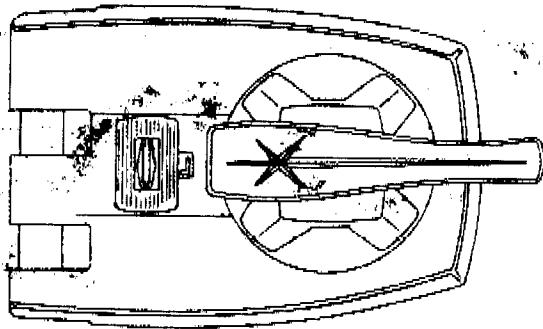

DB9284AP AUTOMATIC DOUBLE  
CYLINDER JIMMY PROOF LOCK

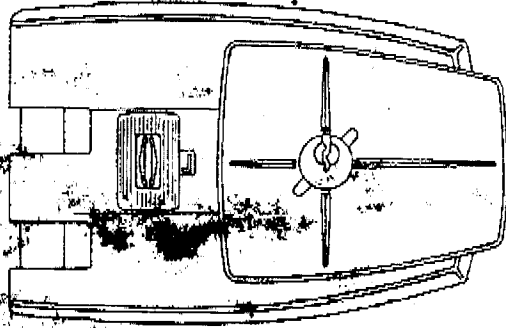

Ideal Security Hardware Corporation  
215 East Ninth Street, St. Paul, Minn. 55101  
PHONE 612-227-7503

A SUBSIDIARY OF  
**EAC**  
INDUSTRIES, INC.

RF0619A

**IDEAL SECURITY  
HARDWARE**

# ORIGINAL INSTALLATION INSTRUCTIONS

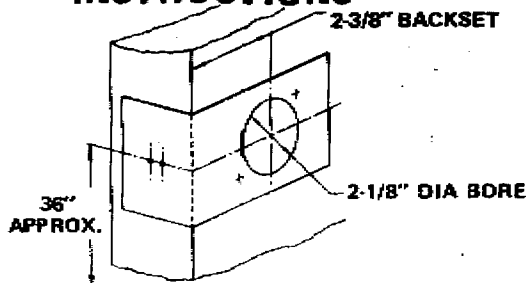

Recommended height of lock is 36" to 38" from bottom of door. Cut out template and fold on dotted line. Place template on the inside of door. Mark center holes on door for lock and ball catch. Bore holes at proper locations. To complete installation, follow replacement instruction.

**NOTE:** For steel jamb application template must line up with strike recess in jamb.

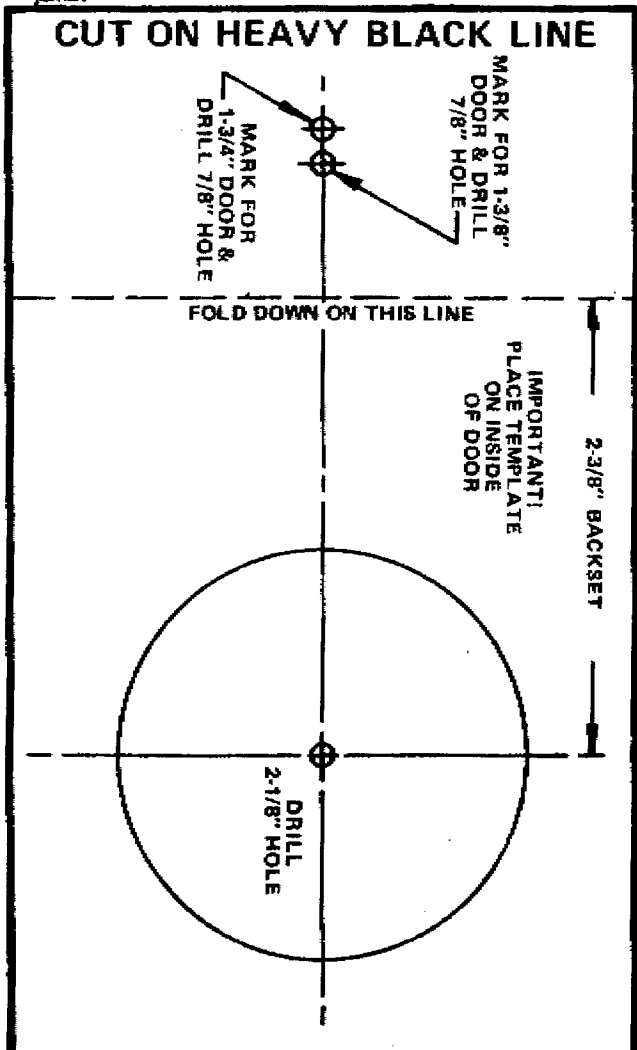

DRILLING TEMPLATE

This instruction sheet is valuable. It will assure your being able to mount and operate your lock properly at all times. We suggest you keep it with other valuable papers. Read completely and understand before starting to install lock.

**CAUTION**  
We suggest, when at home, the key be left in the inside cylinder for emergency exits.

## AUTOMATIC DOUBLE CYLINDER JIMMY PROOF LOCK

FOR INSWINGING WOOD DOORS AND FRAMES ONLY

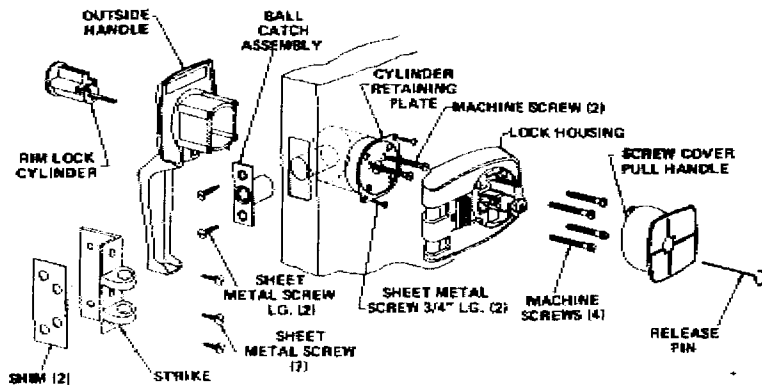

### TOOLS YOU MAY NEED

Electric Drill  
1/8" and 3/32" diameter drill bit  
Expansion Bit for 7/8" dia.—  
2-1/8" dia. or Boring Jig for  
2-1/8" bore and 2-3/8" backset.  
(Available at most hardware stores.)

Wood Chisel  
Hammer  
Pliers  
Screwdriver

RF0619A

## OPERATION OF LOCK

Disengage cross bolt by turning key in either direction from inside or out.

Cross bolt stays disengaged until door is opened and closed again.

When door is open, lock button may be placed in "L" (Locked position). This will permit repeated opening and closing of the door without unlocking each time.

To switch to automatic locking, slide button to "O" (Open position).

Now, when door is closed, the cross bolt will automatically engage strike when actuating lever is depressed by contacting strike.

When door is closed, lock button may be placed in "L" (Locked position) preventing exit from inside or entry from outside with a key.

If after a period of time lock fails to function because bolt does not engage strike, it may be due to door shrinkage and/or loosening of the four machine screws that hold the lock housing to door. See REMOVAL OF SCREW COVER PULL HANDLE, align lock, and tighten securely. It may be necessary to shim under strike.

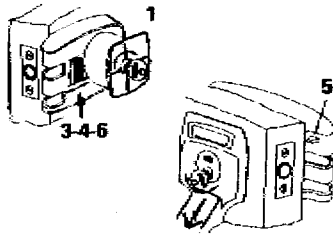

4 NOTE: This lock functions on right or left hand door as assembled in the factory. When using on right hand door, the lock unit may be reversed to allow key to be inserted in same manner as outside lock. See REVERSAL OF LOCK UNIT.

Remove screw cover pull handle by turning clockwise to stop, and remove. Remove caution label from lock housing. Place lock housing on door, guiding tailpiece into back of lock housing. Insert four machine screws, holding housing straight with door edge and tighten screws slightly. Check function of lock by inserting key into lock cylinder and turning key. Do same with outside rim lock cylinder. Lock will turn easier if actuating lever is depressed.

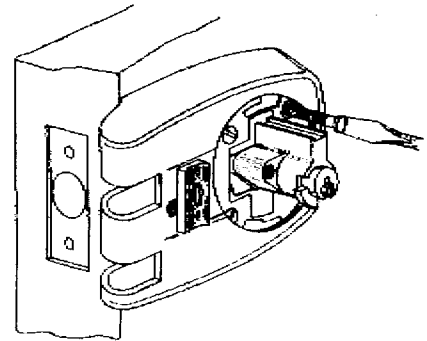

## REPLACEMENT OF EXISTING KEY-IN-KNOB SET

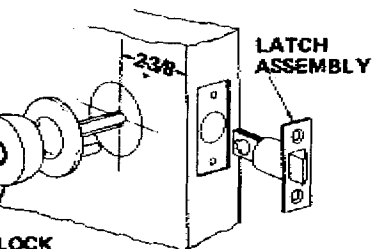

Remove conventional knob lock set, latch assembly, and strike from jamb.

NOTE: On conventional knob lock set, standard bore is 2-1/8" diameter. If diameter is less than 2-1/8", hole must be enlarged to 2-1/8". If backset is other than 2-3/8", hole must be elongated to allow lock set to be positioned at 2-3/8" backset. See template for lockset dimension.

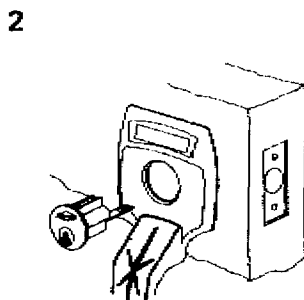

Insert rim lock cylinder, as shown, into handle opening and hold in place on door.

5 Place strike in lock housing and lock cross bolt. Position strike so there is clearance all around cross bolt and extra clearance as illustrated for possible sagging of door. (See Fig. A.) Many doors have sufficient clearance so as not to require the strike to be mortised into door jamb. With strike in position, close door and mark outline of strike on door jamb with a pencil. If strike will not fit between door edge and door jamb, it may have to be swung 90° to mark for height location only. (See Fig. B.) Some types of molding and door jambs may have to be mortised with a sharp chisel to complete installation. (See Fig. C.) Remove strike from lock housing. Check strike for proper position before securing in place with seven screws. Shims are furnished to provide proper projection of strike to lock housing if necessary. For ease in driving screws, it may be desirable to drill a 1/8" pilot hole. With strike secured, close door and make final adjustments before firm tightening four screws on lock completely. Repeat tightening of the four screws until all are tight. Check all functions.

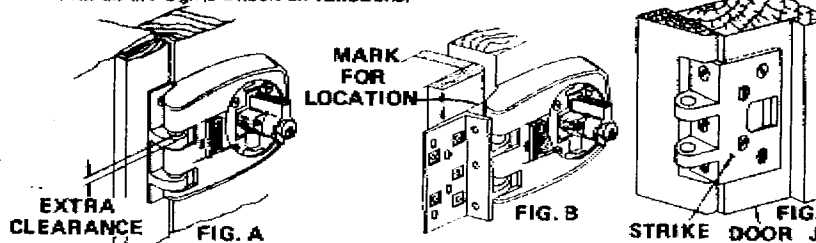

For doors 1-3/4" thick, place cylinder retaining plate in correct position with "TOP" up. With the outside handle and key plug in a vertical position, slightly tighten rim lock cylinder to cylinder retaining plate with two machine screws. Align retaining plates' four holes in line with screw holes in handle. Tighten screws. Spot and drill 3/32" holes for fastening cylinder retaining plate to door with two screws as illustrated. Recheck machine screws for tightness.

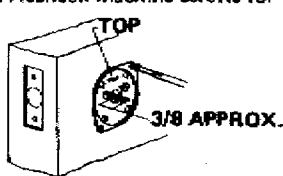

NOTE: For doors under 1-3/4" thickness, it will be necessary to shorten tailpiece. Cut or break tailpiece approximately 3/8" projection from recess of retaining plate.

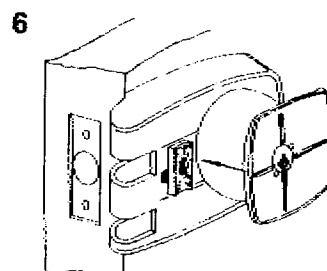

Place screw cover pull handle in position on lock housing. Push in slightly and turn handle counterclockwise until secured. If it becomes necessary to remove the handle, see REMOVAL OF SCREW COVER PULL HANDLE.

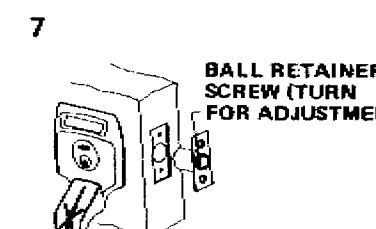

Insert ball catch into hole vacated by latch assembly. Fasten in place using two screws. Close door - ball catch should engage firmly in strike seat. If necessary, adjust by using a screw driver to turn ball retainer located on face of ball catch. An occasional drop of oil on ball will improve operation and extend life.

## REMOVAL OF SCREW COVER PULL HANDLE

**NOTE:** The lock spring will always be located under the release pin opening which is blocked when the key is not turned.

1. Place key into lock housing key plug.
2. Turn key to open lock and leave key in this position.
3. Place release pin in proper opening as indicated by NOTE above.
4. Place release pin on lock spring as shown. While firmly pushing down on lock spring, rotate pull handle clockwise.
5. When pull handle is released, remove release pin and key from lock. Remove pull handle.
6. Refer to #6 of instructions to replace screw cover.

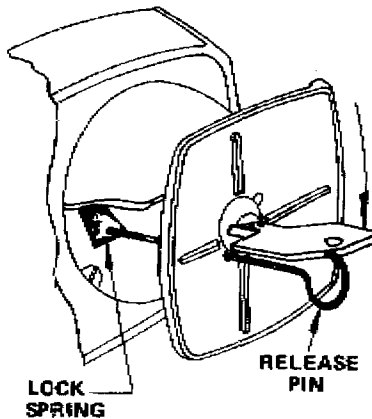

(RETAIN THESE INSTRUCTIONS FOR FUTURE USE)

## REVERSAL OF LOCK UNIT

All locks are factory assembled for a left hand door, (See Fig. A), (lock tumbler pins are on top of keyway). If lock is to be mounted on a right hand door, the lock unit may be rotated 180°. (See Fig. B)

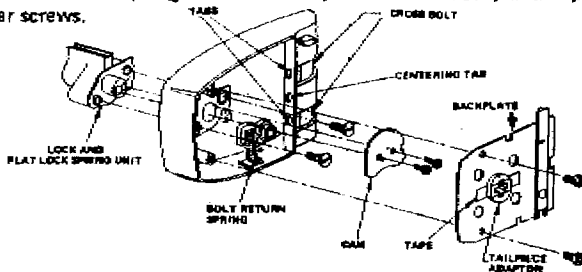

FIG. A



FIG. B

1. Be sure cross bolt is in closed position. See OPERATION OF LOCK.
2. Remove key from lock plug.
3. Place a piece of tape over the tailpiece adaptor to assure proper re-alignment of cam.
4. Remove two screws from back plate and lift out. (Take note of plate position under tabs.)
5. Remove bolt return spring carefully.
6. Remove two screws from cam and lift out. (Take note of cam position.)
7. Remove the two exposed screws and remove lock and flat lock spring unit.
8. Rotate lock and spring unit 1/2 turn, as shown above, and replace using proper screws.



9. Replace cam in original position, see illustration above, fasten securely in place, and tighten screws. Add lubricant to cam if necessary.
  10. Replace bolt return spring.
  11. Replace back plate in correct position, under tabs, using proper screws.
  12. Remove tape and check functions of lock.
- See installation instructions for mounting lock.